

JOGGING



BRPA

Automatic Jogger Type BRPA

Increase of productivity through networking of working processes

EUROCUTTER® Cutting Systems do not only make work easier, but also increase productivity.

Increase of productivity by precise alignment

To increase quality and maximize output quality, jogging is an important feature. With EURO CUTTER Automatic Joggers, the printed sheets are precisely aligned to guarantee exact preparation of the printed sheets. Due to heavy duty machine frame construction, both high impact strength and short jogging times are guaranteed even for difficult materials.

Characteristic features BRPA

Table surface in stainless steel

Including air nozzles in table and both side lays

Automatic, pneumatically tilting side lays on both sides

Table inclination left / right

Adjustable for 3 positions in each direction

Infinitely adjustable jogging power

Direction of jogging engine

Clockwise or counter-clockwise turning selectable

Blower air ON/OFF selectable during jogging

Air ON only when loading / unloading, always ON or always OFF

Motor driven press roller unit

Frequency controlled press roller unit with adjustable speed and pressure

Intermittent air removal in tilted jogging position

Clamp for press rolling unit

Air removal with one open side lay (oversized format)

Number of press rolling operations selectable (0,1,2)

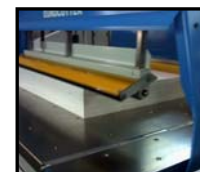

Gauge for press rolling pressure
Adjust the pressure for main pressing



CE-Norm



OPTIONAL BRPA

- **Hydraulic Jogger** Table tilt infinitely adjustable
Including operating panel with display and error messages
Timer function, energy saving mode, storing of up to 10 jobs including all jogging parameters
- Quantification with weight/counting system
- Flaps for gripper system
- Material unloading to the rear (Type BRPA-H)
- Multifunctional press roller jogger equipped with separating gauge (Type BRPA-T)

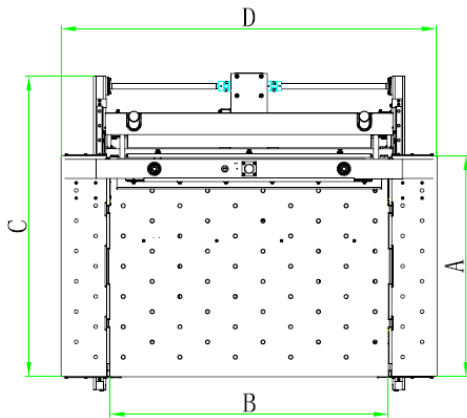

BRPA		-2	-4	-6
A	mm Inches	725 28 ½	905 35 ½	1135 44 ½
B	mm Inches	870 34 ¼	1150 45 ¼	1450 57
C	mm Inches	1120 44	1240 48 ¾	1520 59 ¾
D	mm Inches	1270 50	1550 61	1850 72 ¾

EUROCUTTER BRPA		-2	-4	-6
Format Size	mm Inches	725 x 870 (1070*) 28 ½ x 34 ¼ (42*)	905 x 1150 (1350*) 35 ½ x 45 ¼ (53*)	1135 x 1450 (1650*) 44 ½ x 57 (65*)
Platzbedarf Space required	mm Inches	1120 x 1270 44 x 50	1240 x 1550 48 ¾ x 61	1520 x 1850 59 ¾ x 72 ¾
Einsatzhöhe Max. stack height	mm Inches	165 6 ½	165 6 ½	165 6 ½
Elekt. Leistung Electrical power	Kw HP	1,10 1,47	1,10 1,47	1,75 2,35
Gebläse Blower	l / min l / min	800	800	1200
Luftverbrauch Air consumption	l / min l / min	9	9	13
Gewicht Weight	Kg lbs	450 992	550 1212	730 1609
Spannung Voltage	V	3Ph 200 – 420 V 50 / 60 Hz	3 Ph 200 – 420 V 50 / 60 Hz	3 Ph 200 – 420 V 50 / 60 Hz

* using table and one open side lay
Specifications are subject to change without notice.



MZE Maschinenbau GmbH & Co. KG
Siemensstr. 21
D-65779 Kelkheim / Germany
Telefon +49 6195 994210
Fax +49 6195 994240
Email info@eurocutter.de
Internet http://www.eurocutter.de

