

LOADING



SHH-TE

PALETT TRUCK LIFT SHH-TE

Increase productivity through networking of working processes

EUROCUTTER® Cutting Systems do not only make work easier, but also increase productivity.

Automatic lifting, lowering and automatic loading

Pallet lifts and loading units reduce physical labour. The cutting material is lifted quickly and automatically to the optimal working height and transferred to the High Speed Cutter or other peripheral equipment.

Operator bending is eliminated with an enormous increase of productivity



Machine details SHH-TE

2 in 1 Stacklift and pallet truck lift in one unit

Manuel movable with full load

Very economic

and save due to additional handles

Electrohydraulic automatic lifting/lowering

Eliminating operator fatigue, ensuring continuous work at optimal working height

Integrated battery and charger unit

long life, almost maintenance-free

Quick palette change

due to high lowering speed

Automatic safety cut-off

Integrated power socket

for direct connection to AC

Break



CE-Norm Safety Standard



Options:

Different types

fork-lengths from 600 to 1520 mm, lifting heights from 920 up to 3300 mm

EUROCUTTER®		-1150	-800
SHH-TE			
Tragkraft	kg	1000	1000
Lifting capacity	lbs	2200	2200
Gabellänge	mm	1150	800
Forklength	inches	45	31 ½
Gabelbreite	mm	560	560
Forkwidth	inches	22	22
Maximale Hubhöhe	mm	920	920
Max. lifting height	inches	36	36
Hebezeit, beladen	sec.	12	12
Lifting time with load			
Hebezeit, unbeladen	sec.	7	7
Lifting time without load			
Senkzeit, beladen	sec.	9	9
Lowering time with load			
Senkzeit, unbeladen	sec.	11	11
Lowering time without load			
Gewicht mit Batterie	kg	222	202
Weight with battery	lbs	489	447

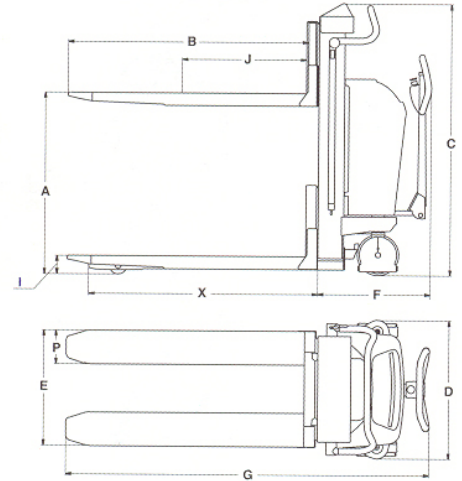

Specifications are subject to change without notice



MZE Maschinenbau GmbH & Co. KG
 Siemensstr. 21
 D-65779 Kelkheim / Germany
 Telefon +49 6195 994210
 Fax +49 6195 994240
 Email info@eurocutter.de
 Internet http://www.eurocutter.de

